



STREET LIGHT SERIES

XLD-L004B



● Structural characteristic

1. 700t die casting aluminum housing, with high intensity, concise structure and streamline outline
2. Hi-purity aluminum reflector, polished and anodized
3. Tempered glass lens, with the characteristic of good transparency, high temperature resistant and uniform light
4. Lens and shell connected with stainless steel hardware, easy to install and maintain
5. Sealed with foamed silicon rubber, with excellent waterproof and dustproof performance

● Technical Parameters

1. IP rating:
Control gear compartment: IP65
Optical compartment: IP66
2. Level of Corrosionproof: II
3. Working environment: -35°C ~ +45°C
4. Electric shockproof rating: I
5. Lampholder: E27 E40
6. Voltage: 110V-130V/60Hz 220V-240V/50Hz
7. Illuminant: 70W-400W HPS/MHL/Mercury lamp

● Dimensions(mm)

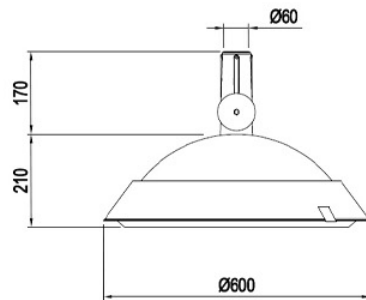

● Photometric Data

